

A MATRIX REPRESENTATION OF THE CPM/PDD APPROACH AS A MEANS FOR CHANGE IMPACT ANALYSIS

C. Köhler, J. Conrad, S. Wanke and C. Weber

Keywords: engineering change management, change impact analysis, configuration, matrix-CPM/PDD

1. Introduction

Engineering changes occur in every life cycle phase of a product and in every step of the product development process. Today, the importance of engineering change management as a part of product development is constantly rising. Reasons besides the globalisation are that customers are interested in more customised products at the price of a mass product - a phenomenon [Eckert et al. 2003] call mass customisation -, failures in design and changes in customer wishes that can not entirely be prevented.

According to Lindemann and Reichwald [Lindemann et. al. 1998] engineering change management consumes 30 to 50 %, sometimes even up to 70 % of the capacity in product development. According to Wildemann [Wildemann 2006] the average cost of one engineering change is about 1.400 EUR (working hours, scrapping and tooling cost, but no organisational cost). Multiplied with 425 changes per month in average, identified by Deubzer et. al. [Deubzer 2005], that results in 7.1 million EUR change cost per year for an average company in the automobile manufacturing industry.

According to the rule of ten [VDI2247], engineering changes become more expensive and time consuming the later they occur in the product life. Hence, it is advantageous to perform changes as early as possible [Lindemann et al. 1998]. But on the other hand, today's markets and customer wishes change so quickly that a frontloading of engineering changes hinders the technological development of a company and endangers competitive advantages through innovation and customisation. Additionally, again according to Lindemann and Reichwald [Lindemann et. al. 1998], about 40 % of changes are recognised only after the completion of the production tools. That is supported by Wildemann [Wildemann 2006] who states that 50 % of the design-related changes happen in the pre-series and series phase of the product development process.

Approaches like Design for Changeability help to reduce change cost but even can not foresee all possible changes. Therefore, (engineering) change management is still an important task in product development. Thereof, especially the area of change impact analysis is the most significant part.

2. Engineering change management and engineering change process

According to Jarrat et al. [Jarrat et al. 2005], "engineering change management refers to the organisation and control of the process of making alterations to products". The reasons for making alterations to products can be error correction, performance improvement, mass customisation, introduction of new or improved products by a competitor, technological changes, cross-domain inspiration [Eckert et al. 2003], changes in the supply chain, changes in legislation, innovation etc.

Jarrat et al. [Jarrat et al. 2005] propose a six-phase engineering change process, which is depicted in Figure 1. After raising an engineering change request, possible change solutions must be identified.

After that, the risks and impacts of the possible change solutions must be assessed. An incontrovertible precondition for the assessment of the change solutions is the performance of a change impact analysis. The quality of this analysis is directly related to the quality of the assessment and thus the selection and approval of a change solution, which is implemented and reviewed after the approval.

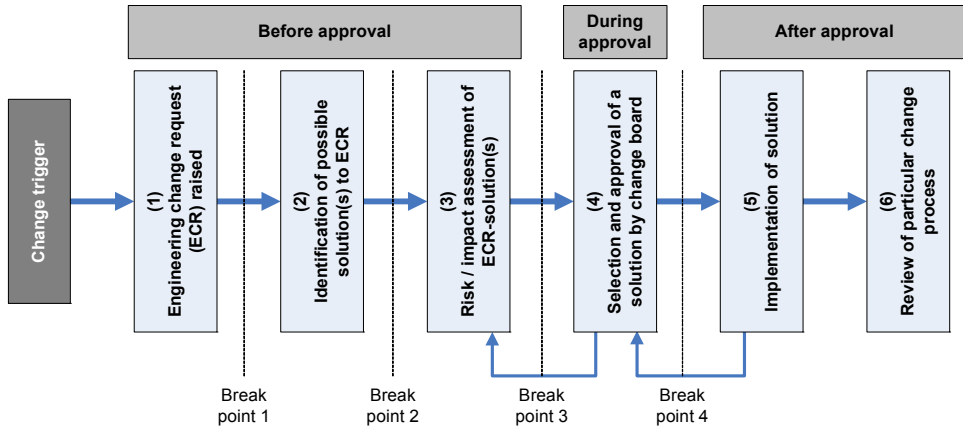

Figure 1. A generic engineering change process (following [Jarrat et al. 2005])

This contribution focuses on the change impact analysis based on a matrix-representation of the Characteristics-Properties Modelling / Property-Driven Development approach which is presented in the following section.

3. The matrix representation of the Characteristics-Properties Modelling / Property-Driven Development approach (Matrix-CPM/PDD)

This section gives a brief introduction of the Characteristics-Properties Modelling / Property-Driven Development approach of Prof. Christian Weber, developed at Saarland University.

3.1 Characteristics-Properties Modelling / Property-Driven Development

The Characteristics-Properties Modelling / Property-Driven Development (CPM/PDD) approach can be used in product development to model products and product development processes. Core of the CPM/PDD theory is a clear distinction between characteristics and properties:

- *Characteristics* (C_m) describe the shape and the structure of a product (e.g. geometry, BOM, materials etc.) and can be directly established, assigned and modified by the designer.
- *Properties* (P_n) describe the behaviour of a product (e.g. weight, manufacturability, function, cost, user friendliness etc.) and can not be directly established by the designer; they can only be indirectly influenced by changing the depending characteristics.

To represent the interrelations between characteristics and properties *relations* (R_n) are used. Thus, characteristics, relations and properties can be depicted in a network-like structure (see Figure 2).

Thereby, two types of relations between characteristics and properties can be distinguished:

- based on given/required properties *synthesis* aims at establishing or assigning appropriate product characteristics, and
- based on known/given characteristics of a product, analysis determines its properties.

The CPM/PDD approach explains product development as a sequence of synthesis, analysis and evaluation steps. In each evaluation step one or more property values (it is not always possible to measure a property by a countable value, e.g. the haptic of a surface) are compared with the required properties (RP_n). The difference between the existing and the required properties (ΔP) indicates which properties need to be customised by modifying the related characteristics. Thus, this difference is the driver of

the process. *Dependencies* (D_x) depict the internal relations between characteristics. *External conditions* (EC_n) represent external influences on the design. For a more detailed description of the CPM/PDD theory see [Weber 2005].

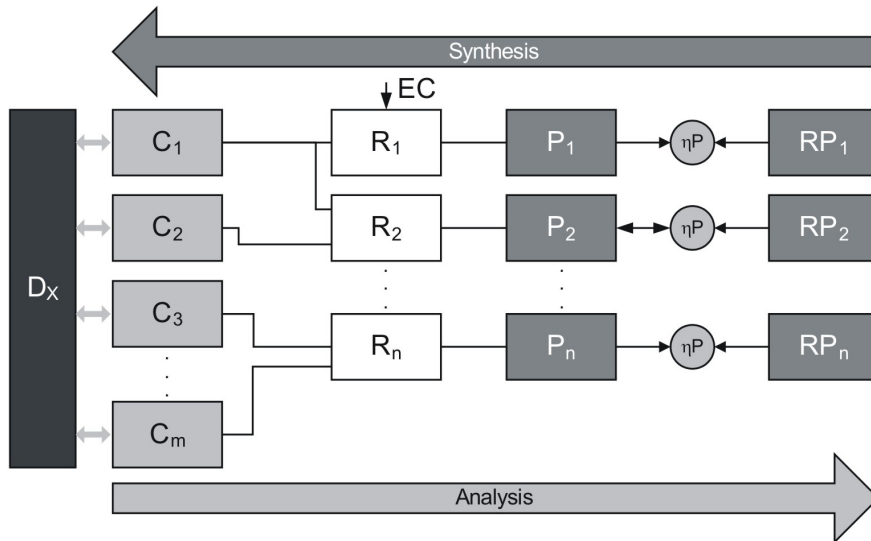

Figure 2. The CPM/PDD-model

3.2 Matrix representation

The result of a PDD-project is a detailed network of characteristics and properties. By using the traditional box-representation the network appears quite complex and is difficult to handle. This can be seen already at the simple example of a bearing shown in Figure 3. It is easy to imagine that the depiction of a whole product including that bearing will be much more complex. Therefore a different representation could be helpful and will be introduced in this contribution.

In order to develop an improved representation, the Design Structure Matrix (DSM) can be taken as a source of inspiration. The DSM is a means to represent and analyse task dependencies as well as development projects at the task level [Ulrich and Eppinger 2004] and is able to keep complex structures readable, understandable and manageable. In the context of the aspired application of CPM/PDD in the area of change impact analysis, a matrix representation is expected to lead to similar advantages as experienced by using the Matrix-FMEA [Johne and Ziegelowski 2000]:

- The matrix-based analysis is more efficient and not that time-consuming.
- The changed representation leads to an improved quality of the result.
- The matrix representation is quite compact, thereby arranged more clearly and therefore more easily to comprehend/retrace.
- The matrix representation simplifies the search for potential solutions and side effects.

In order to develop a matrix representation of the CPM/PDD approach, a distinction has to be made between the product model (CPM) and the process model (PDD).

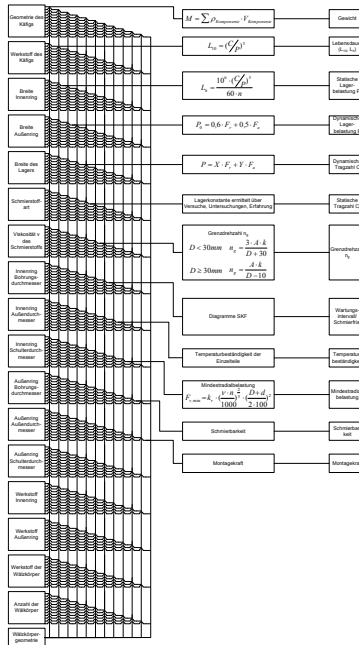

Figure 3. CPM model of a bearing

3.2.1 CPM – The product model

The product model includes the characteristics, properties, relations and dependencies that describe the product. In order to represent the product, two matrices are needed. One is used for the depiction of the relations and the other for the dependencies between the characteristics. The list of characteristics is on its left hand side connected to the dependencies matrix and on its right hand side to the relations matrix, i.e. the characteristics are in the row of the relations matrix (also called CPM/PDD-matrix). Hence, the relations, external conditions and properties are connected to the columns of the relations matrix. This is possible because it is a precondition of CPM that one property is always connected to one relation. The CPM matrix representation is shown in Figure 4.

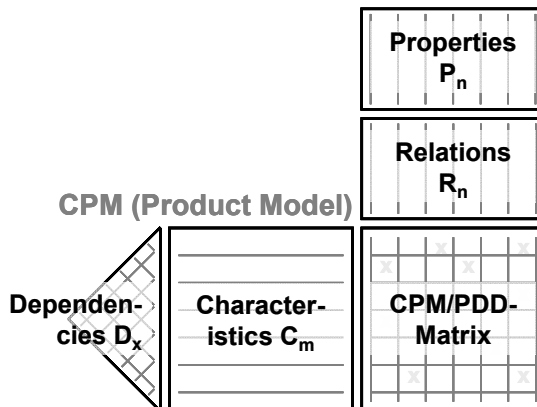

Figure 4. Matrix representation of the product model (CPM)

3.2.3 PDD – The process model

The process model describes the development of the product by using analysis, synthesis and evaluation steps. Usually, a design process starts with a list of requirements (properties required). According to the PDD approach [Weber 2005] the first synthesis step defines a first set of characteristics. Based on these the following analysis step determines as-is-properties. In an evaluation step the determined as-is-properties get compared to the required properties. The result of the evaluation is the difference between the determined and required properties (ΔP) which is the driver for the next development loop. So, loop by loop the product gets more detailed.

This concept of the development process can also be depicted by matrices. The reasoning in doing so is that the matrices are easily expandable, without losing the advantages described earlier, and that the structure of the matrices supports even the case of an unequal number of characteristics and properties. The matrix representation of two PDD development loops is shown in Figure 5.

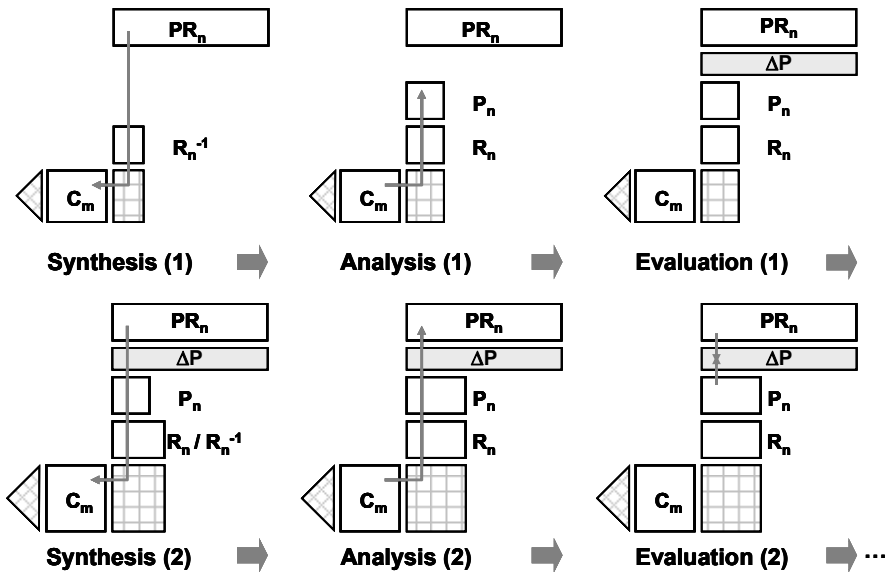

Figure 5. Matrix representation of the process model (PDD) – Loop 1 and 2

4. Change impact analysis with Matrix-CPM/PDD

Based on the introduced matrix representation of the CPM/PDD approach (Matrix-CPM/PDD), several additional fields of application are possible. One of these is the broad analysis of engineering changes. The usability of the CPM/PDD approach for engineering change management was already shown by the authors at the ICED07 conference [Conrad et al. 2007]. There, a method called Change Impact and Risk Analysis (CIRA) was introduced. In order to improve its part of change impact analysis Matrix-CPM/PDD can be used.

Generally, every element of the CPM/PDD approach can be addressed by an engineering change request (ECR) (see [Conrad et al. 2007]), but this contribution focuses on changes of the required properties which are assumed to be the most frequent ones.

The third step of the generic engineering change process as depicted in Figure 1 is the assessment of risks and impacts of solution(s) to an ECR. Preconditions for the assessment of impacts are the identification of possible solutions to the ECR and a well-founded analysis of the solutions' impacts. Both steps can be supported by Matrix-CPM/PDD.

This contribution explains generally, how solutions to an ECR can be identified and how their impacts can be analysed by using Matrix-CPM/PDD. The explanation can be traced in Figure 6. The whole

approach is based on the result of PDD process, a CPM-product model, documented in Matrix-CPM/PDD. In order to perform a change solution identification and impact analysis Matrix-CPM/PDD is extended due to the needs of the engineering change process (see Figure 6).

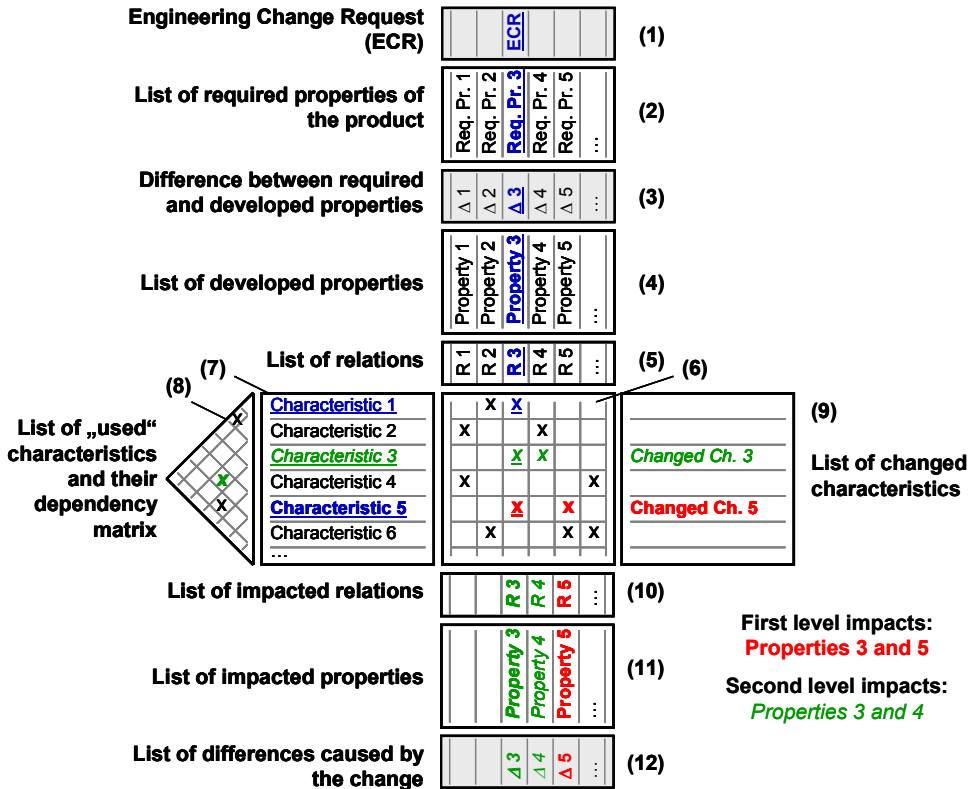

Figure 6. Change solution identification and impact analysis with Matrix-CPM/PDD

- *Step 1:* The first step after the initiation of an ECR is to register the ECR and to identify the required properties which are modified by the ECR. Therefore the ECR is written above the initial representation of Matrix-CPM/PDD (array (1) of Figure 6): the required property 3 is affected by the ECR.
- *Step 2:* The second step is to identify the new difference between the current as-is-property and the required property as modified by the ECR. Here, it is to decide whether any change (of the characteristics) is at all necessary or not. In case that the existing property already fulfils the change request a change is not necessary, i.e. the initial solution obviously has enough reserves to cope with the modified requirements. In Figure 6 the $\Delta 3$ in row (3) is re-specified and it is decided that further change is necessary.
- *Step 3:* After the decision that a change is necessary, the characteristics which influence the property to be changed are detected by tracing backwards via the relation to the relation matrix where the crosses show the appropriate characteristics (rows (4), (5) and matrix (6) in Figure 6).
- *Step 4:* Next to the identification of the influencing characteristics, solutions to the change request can be developed. This can be done through varying (e.g. using the variation rules according to Ehrlenspiel), add or omit characteristics or even replace whole sets of characteristics – which could even lead to new solution patterns, e.g. machine elements.

Figure 6 shows that property no. 3 is influenced by the characteristics nos. 1, 3 and 5 (matrix (6) and column (7)). Assumed that the design team decides to change characteristic no. 5, its new value is written in column (9).

- *Step 5:* The fifth step is about the identification of the other properties impacted through the changed characteristic(s).

The relations matrix of the example shows that characteristic no. 5 influences property no. 3 (as intended) and furthermore property no. 5 (rows (10) and (11)).

- *Step 6:* Subsequently, a check whether the intended change is successful ($\Delta P \rightarrow 0$) has to be done and it has to be checked, whether the success is at the expense of other ΔP . In case of a flop, the change solution has to be reconsidered, rejected or supported by a second changed characteristic. In case of success, the other impacts have to be checked whether they are acceptable (row (12) in Figure 6). These impacts are *first level impacts*.
- *Step 7:* Next, the *second level impacts* have to be determined. In order to do so, it has to be checked whether the change of a characteristic has additional impacts on other characteristics via the dependencies matrix and how they look like.

Figure 6 depicts a dependency between characteristic no. 5 and no. 3 (matrix (8)). Thus, there is an impact. The new value of characteristic no. 3 is documented again in column (9).

- *Step 8:* Again, with support of the relation matrix, it has to be analysed which properties are impacted by that second level change. Then, it has to be analysed how that change impacts all properties.

Characteristic no. 3 is related to the properties no. 3 and 4 (matrix (6), rows (10) and (11)). So, in that particular case, we have to check whether the additional influence on property no. 3 still leads to the fulfilment of the ECR (row (12)). In case of fulfilment, it has to be checked whether the change of property 4 is also acceptable.

Generally, there are also third level changes through change impacts on relations or external conditions, but they are not discussed in this paper.

The eight steps explained have to be run through for every change solution that is to analyse. Based on this process, it is possible to decide which of the solutions has the fewest or most favourable impacts.

5. Discussion and Future Work

The use of the CPM/PDD approach provides a scheme that enables designers to track down impacts of an ECR. Matrix-CPM/PDD contributes to this by making the analysis more user-friendly, reducing the perceived complexity of the CPM/PDD network, thus helping to prevent mistakes during the analysis. In contrast to Suh's Axiomatic Design approach, with the CPM/PDD approach it is even possible to analyse second or third level change impacts. Furthermore, the use of Matrix-CPM/PDD enables the designers to use CPM/PDD without having a special computer tool. Matrix-CPM/PDD can be performed with every spreadsheet-tool (e.g. MS Excel or OpenOfficeCalc) and, thus, can contribute to the industrial acceptance of the CPM/PDD approach.

But there is still some work to do: The analysis of the change impacts on relations and external conditions has to be integrated and the change processes with other change triggers (i.e. changed characteristics, relations or external conditions) have to be investigated. Furthermore, the change impact analysis has to be tested with more cases and by that to be improved in usability and performance. Moreover, changes that affect several products have to be integrated in the method.

References

- Conrad, J., Deubel, T., Köhler, C., Wanke, S., Weber, C., "Change Impact and Risk Analysis (CIRA) - Combining the CPM/PDD Theory and FMEA-Methodology for an Improved Engineering Change Management", *Proceedings of the 16th International Conference on Engineering Design ICED07, Ecole Centrale, Paris, France, 2007, Paper No. 549.*
- Deubzer, F., Kreimeyer, M., Junior, T., Rock, B., "Der Änderungsmanagement Report 2005", *CiDaD Working Paper Series, TU München, 2005.*

- Eckert, C.M., Pulm, U., Jarrat, T.A.W., "Mass Customisation, Change and Inspiration – Changing Designs to Meet New Needs", *Proceedings of the 14th International Conference on Engineering Design ICED03*, Royal Institute of Technology, Stockholm, Sweden, 2003.
- Jarrat, T., Clarkson, J., Eckert, C., "Engineering Change", *Design Process Improvement – A review of current practice*, J. Clarkson and C. Eckert (Ed.), Springer-Verlag London, UK, 2005.
- Johne, S., Ziegłowski, M., "Sicherheit per Matrix", *QZ-Qualität und Zuverlässigkeit*, Jahrgang 45 (2000) 7, Carl Hanser Verlag, München, 2000, pp. 876-882.
- Lindemann, U., Reichwald, R., "Integriertes Änderungsmanagement", Springer-Verlag, Berlin, Germany, 1998.
- Ulrich, K.T., Eppinger, S.D., "Product Design and Development", McGraw Hill Irwin New York, USA, 2004.
- Verein Deutscher Ingenieure (VDI), VDI-Richtlinie 2247, "Qualitätsmanagement in der Produktentwicklung", Entwurf, Beuth-Verlag, Berlin, Germany, 1994.
- Weber, C., "CPM/PDD – An Extended Theoretical Approach to Modelling Products and Product Development Processes", 2. German-Israeli Symposium on Advances in Methods and Systems for Development of Products and Processes, TU Berlin/Fraunhofer-Institut für Produktionsanlagen und Konstruktionstechnik (IPK), Bley, H.; Jansen, H.; Krause, F.-L.; Shpitalni, M. (Ed.), Fraunhofer-IRB-Verlag, Stuttgart, 2005, pp. 159-179.
- Wildemann, H., "Änderungsmanagement – Leitfaden zur Einführung eines effizienten Managements technischer Änderungen", TCW Transfer Centrum, München, Germany, 2006.

Dipl.-Ing. Christian Köhler
 Research Associate
 Institute of Engineering Design/CAD, Saarland University
 Campus A4 2, D-66123 Saarbrücken, Germany
 Tel.: +49 (0) 681 / 302 – 58 303
 Fax.: +49 (0) 681 / 302 – 4858
 Email: koehler@cad.uni-saarland.de
 URL: <http://www.cad.uni-saarland.de>